

New England QRP Club Noise Bridge Project

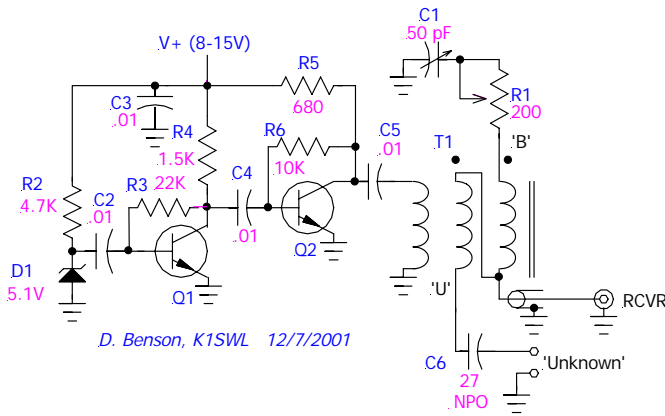

Qty.	Ref. Desig.	Description
1	C1	8-50 pF trim cap, 5mm
4	C2-C5	.01 uF ceramic disk cap
1	C6	27 pF cer. disk cap, NPO
1	D1	0.5W Zener diode, 1N5231B
2	Q1,Q2	2N4401 NPN transistor
1	R1	200-ohm 6mm trim pot
1	R2	4.7K, 1/4W (ylw-viol.-red-gold)
1	R3	22K, " (red-red-org-gold)
1	R4	1.5K, " (brn-grn-red-gold)
1	R5	680 ohm, " (blu-grey-brn-gold)
1	R6	10K, " (brn-blk-org-gold)
1	T1	FT50-43 toroid
1 ea	--	6-32 screw, nut, lockwasher
1	--	nylon cable clamp, 1/8"
1	--	printed-circuit board
1	--	4" length ribbon cable (3-wire)
1	--	16" RG-174 w/ BNC connector.
1	--	9V battery (snap) connector

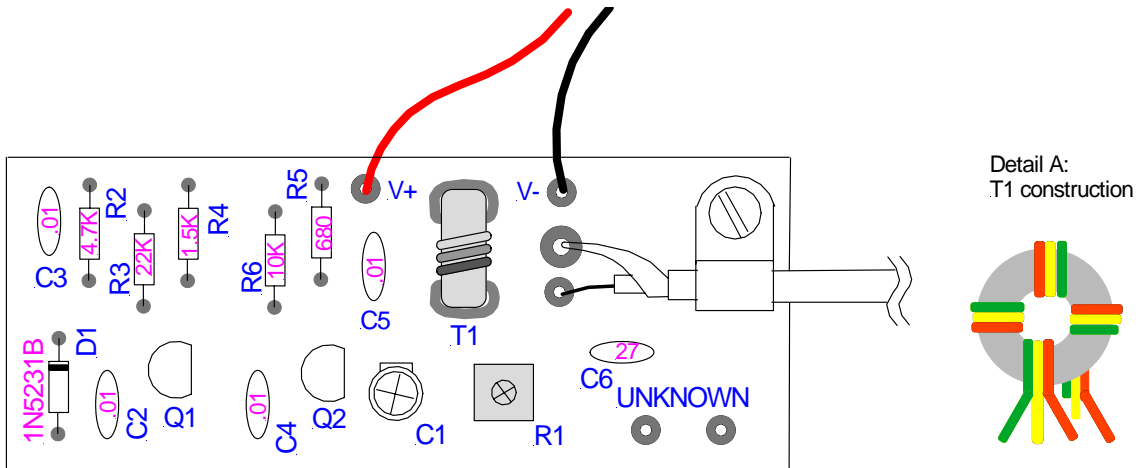

Recommended Assembly Sequence:

1) Install all resistors, capacitors and semiconductors as illustrated above. All components mount on the top (silkscreened) side of the board. **Caution:** the following components are installation orientation-sensitive: C1, D1, Q1, Q2. Match the flat side or banded end of those components to the orientation shown in the drawing above.

2) Wind 4 turns of the supplied length of 3-wire ribbon cable. When complete, it will match the appearance of the toroid sketch above at right. Colors will vary and are non-critical, but ensure that each turn lies flat on the core. Split the wire trio apart with a sharp knife (back to the toroid body). Trim lead lengths to 1/2" (1.5 cm), strip all 6 wire ends. Orient the toroid so that matches the rectangular outline on the printed-circuit board. Install all 6 wires into corresponding through-holes and then solder onto the board.

3) Install battery snap leads for an external 9V battery (not included). Observe the red/black lead polarity as shown. Note: you may use an external DC power supply if you prefer- maximum recommended supply voltage is 15VDC nominal.

4) Using a sharp knife, carefully strip 1" (2.5 cm) of outer jacket from the cut end of the supplied RG-174 cable. Gently unbraid the outer (shield) layer, pull it to one side and twist it into a bundle. Remove a length of the dielectric jacket surrounding the center conductor. Install as shown above with the twisted shield shield installed in the larger-diameter hole as shown. *Note: Inspect your work closely- a single stray strand of braid is sufficient to short out the coax and render the circuit inoperative. Use minimum heat when soldering - the (poly) dielectric material will deform with excess heat.*

5) Install the cable clamp over the RG-174 coax and secure with the supplied machine screw, locknut and hex nut.

6) If you haven't done so as you've installed and soldered components onto the boards, remove excess lead protrusions from the solder side of the board with diagonal cutters.

* * *

Typical Applications:

Antenna trap adjustment: Connect a 100-ohm 1/4W resistor across the 'unknown' terminals and connect to your receiver with a length of coax. Apply DC power (8-15V) to the noise bridge circuit and you should hear a loud rushing noise in the receiver. Adjust control 'R1' for minimum S-meter indication and then 'C1'. Once these are both adjusted carefully, the noise level in the receiver should drop to its internal noise level alone. The noise bridge is now adjusted for a null- the impedance presented by the 100-ohm resistance and stray capacitance is now balanced by the bridge's 'R1' and 'C1' settings.

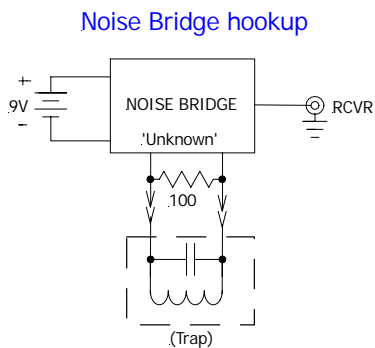

When you add the trap- a parallel L-C circuit- at its resonance frequency across that 100-ohm resistor, there'd be no disturbance to the null since its impedance at the intended operating frequency is theoretically infinite. Away from the resonance frequency, the noise level will rise as the receiver is tuned off to either side. Finding the trap's resonant frequency amounts to tuning your receiver until you've located the noise null. This null will be fairly broad; however, it should be easy to locate using 1-Mhz tuning steps and then tuning more closely for the deepest portion of the null.

Once you've found the null, the trap may be adjusted by changing either inductance or capacitance to modify its resonant frequency to suit your operating preferences. For a trap antenna, you'd normally adjust a resonant trap to the center of the band portion you most often use.

Caution:

It's critical to make the leads from the 'unknown' terminals on the bridge to the traps as rigid as is practical. Use short length 2" (cm) lengths of solid wire to the 100-ohm parallel load- you may install solder lugs outboard of that resistor. This allows the traps to be added and removed with a minimum of change in stray capacitance, which affects the resonance measurement significantly. Unless this precautions is taken, measurements may not be repeatable. *Note- once these trap hookup connections are ready to go and prior to adding the traps, be sure to readjust C1 for a noise null- this effectively tunes out the test setup stray capacitance.*

Antenna tuner adjustment: Using a 51 ohm resistor as a known load at the 'unknown' terminals, adjust C1 and R1 for a noise null. WITHOUT MAKING ANY FURTHER ADJUSTMENTS TO C1/R1, substitute a connection to your antenna tuner and adjust the tuner settings for minimum noise level. When you've adjusted the tuner settings for a noise null, the impedance seen' looking into' the antenna tuner is 51 ohms (i.e., a 1:1 SWR). **Caution:** avoid going 'key-down' with the bridge connected- damage may result . [And no, I don't know what power level will cause that! - it's related to component breakdown voltages and SWR..]